

REVISION RECORD				
REV	ECO	DESCRIPTION	DRFT	CHKD

NOTES:

ELECTRICAL:

- 1 VOLTAGE RATING :125 VAC RMS
- 2 CURRENT RATING :15 AMP.
- 3 CONTACT RESISTANCE :30 MILLIOHMS MAX.
- 4 INSULATION RESISTANCE :1000 MEGOHMS MIN @ 500V DC .
- 5 DIELECTRIC STRENGTH :1000V AC RMS 50HZ 1MIN.

MECHANICAL:

- 1 HOUSING MATERIAL :GLASS FILLED POLYESTER UL94V-0.
  - 2 HOUSING COLOUR :BLACK GRAY YELLOW OR OTHERS
  - 3 CONTACT MATERIAL :PHOSPHOR BRONZE #0.45mm
  - 4 PLATING :GOLD PLATING OVER NICKEL.
  - 5 OPERATING :750 CYCLES MIN.
  - 6 PCB RETENTION PRE-SOLDER :1 LB MIN.
- ENVIRONMENTAL:
- 1 Storage Temperature Range : -40<sup>o</sup>~+85<sup>o</sup>F
  - 2 Operation Temperature Range : 0<sup>o</sup>~70<sup>o</sup>F
  - 3 Wave soldering temperature:245±5~10 seconds)

PART NUMBER:

DY9752 - XX XX X X X - X X X X - L

Part Number

Lead Free

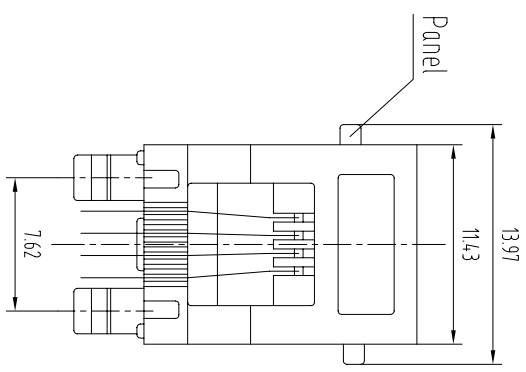
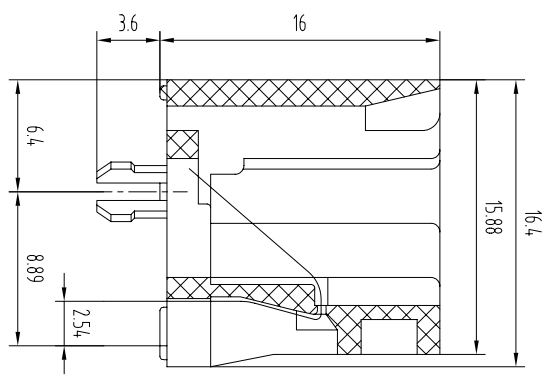
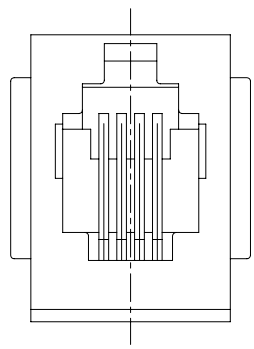
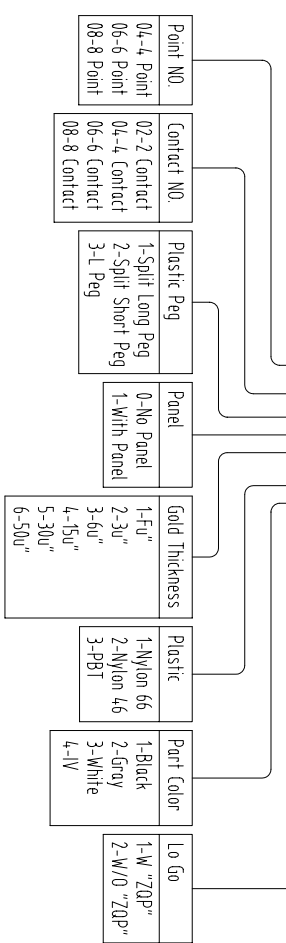

PCB LAYOUT

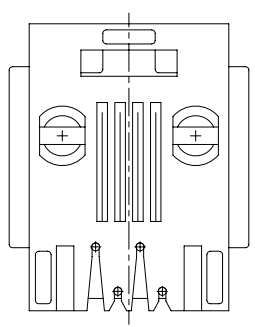
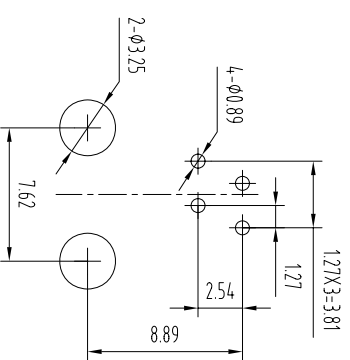

DETACHED LISTS

mm (Inch)		DATE: 2006/01/01		DUOYUAN TELECOM PRODUCTS CO.,LTD		DY9752-0404XX1-32-L	
Tolerance Excpd as Noted		CHKD:	DATE:				
mm	±	APPRV:	DATE:				
0±0.2 00±0.15 000±0.075	±	MATERIAL:					
ANGLES ± 0.5		Q.TY:		DRAWING NO		SIZE	REV
FINISH:		SCALE: 2.5:1		/PART NO		A4	06/03/02
SCALE:		2.5:1		DO NOT SCALE DRAWING		SHEET	OF