

REVISION RECORD				
REV	ECO	DESCRIPTION	DRFT	CHKD

NOTES:

ELECTRICAL:

- 1 VOLTAGE RATING :125 VAC RMS
- 2 CURRENT RATING :15 AMP.
- 3 CONTACT RESISTANCE :30 MILLIOHMS MAX.
- 4 INSULATION RESISTANCE :1000 MEGOHMS MIN @ 500V DC .
- 5 DIELECTRIC STRENGTH :1000V AC RMS 50HZ 1MIN.

MECHANICAL:

- 1 HOUSING MATERIAL :GLASS FILLED POLYESTER UL94V-0.
- 2 HOUSING COLOUR :BLACK GRAY YELLOW OR OTHERS
- 3 CONTACT MATERIAL :PHOSPHOR BRONZE #0.45mm
- 4 PLATING :GOLD PLATING OVER NICKEL.
- 5 OPERATING :750 CYCLES MIN.
- 6 PCB RETENTION PRE-SOLDER :1 LB MIN

ENVIRONMENTAL:

- 1 Storage Temperature Range : -40^o~+85^oF
- 2 Operation Temperature Range : 0^o~70^oF
- 3 Wave soldering temperature:245-55~10 seconds)

PART NUMBER:

DY9752 - XX XX X X X - X X X - L

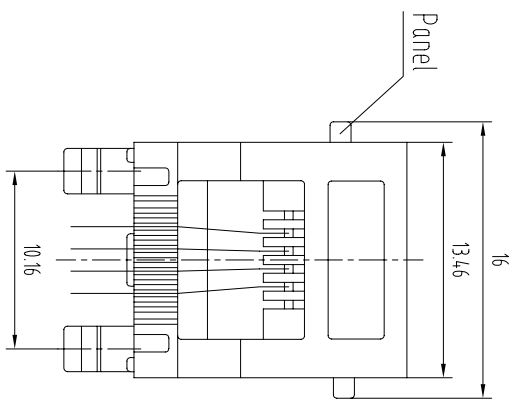
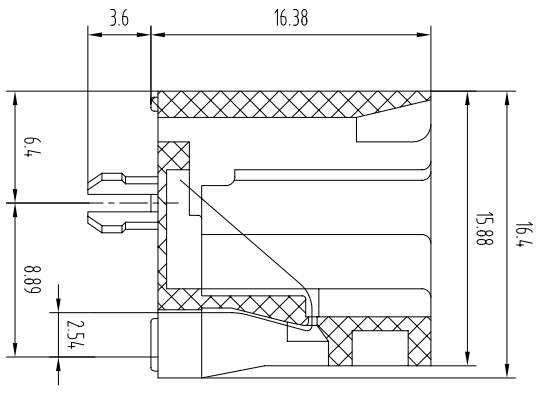
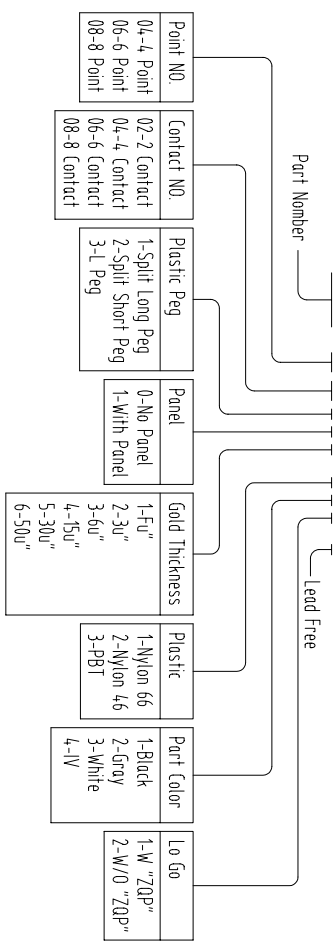

PCB LAYOUT

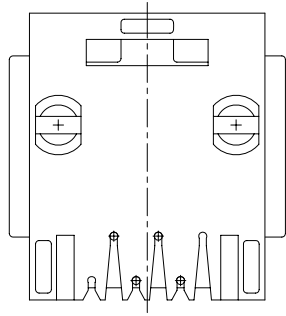
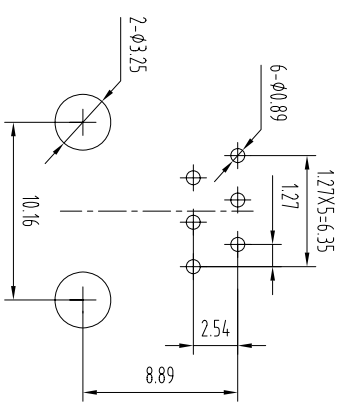

DETACHED LISTS

<p>mm (Inch)</p> <p>Tolerance Excp. as Noted</p> <p>mm 0±0.2 00±0.15 000±0.075</p> <p>ANGLES ± 0.5</p>		<p>DATE: 2006/01/01</p> <p>DATE:</p> <p>DATE:</p>	<p>DUOYUAN TELECOM PRODUCTS CO.,LTD</p> <p>DY9752-0604XX1-32-L</p>
<p>APPROV:</p> <p>DATE:</p>	<p>DATE:</p>	<p>DRAWING NO</p> <p>/PART NO</p> <p>SCALE: 2.5:1</p>	
<p>SIZE A4</p> <p>REV 0</p>	<p>SIZE A4</p> <p>REV 0</p>	<p>DO NOT SCALE DRAWING</p>	<p>SHEET 1 OF</p>