



SPECIFICATION FOR APPROVAL

DELEC		
MARKETING GROUP	R&D GROUP	QA GROUP
ISSUED BY	CHECKED BY	QA INSPECTION
Star Yan	Weide Li	Tian Ming

CUSTOMER

CUSTOMER APPROVAL:

APPROVAL
 CONCESSIONARY
 REJECTED

ISSUED BY : _____

CHECKED BY: _____

APPROVED BY: _____

COMMENTS : _____

CUSTOMER: _____

CUSTOMER PART NO: _____

SAMPLE Q'TY: _____

TITLE 4P4C SIDE ENTRY PCB JACK WITHOUT SHIELDED				东莞多亚电子有限公司 DONGGUAN DUOYA ELECTRONICS CO., LTD				
PART NO. DY9755-1D21038-001				GENERAL TOLERANCE			UNIT:MM(INCH)	SIZE: A4
DRAW	Star	DATE	2015-06-23	.X±0.20	.X±1°	SCALE: 1:1	SHEET: 1/4	REV:A
CHECK	Eric	DATE	2015-06-23	.XX±0.15	.XX±0.5°			
APPROVE	De	DATE	2015-06-23	.XXX±0.10				

MECHANICAL DIMENSION

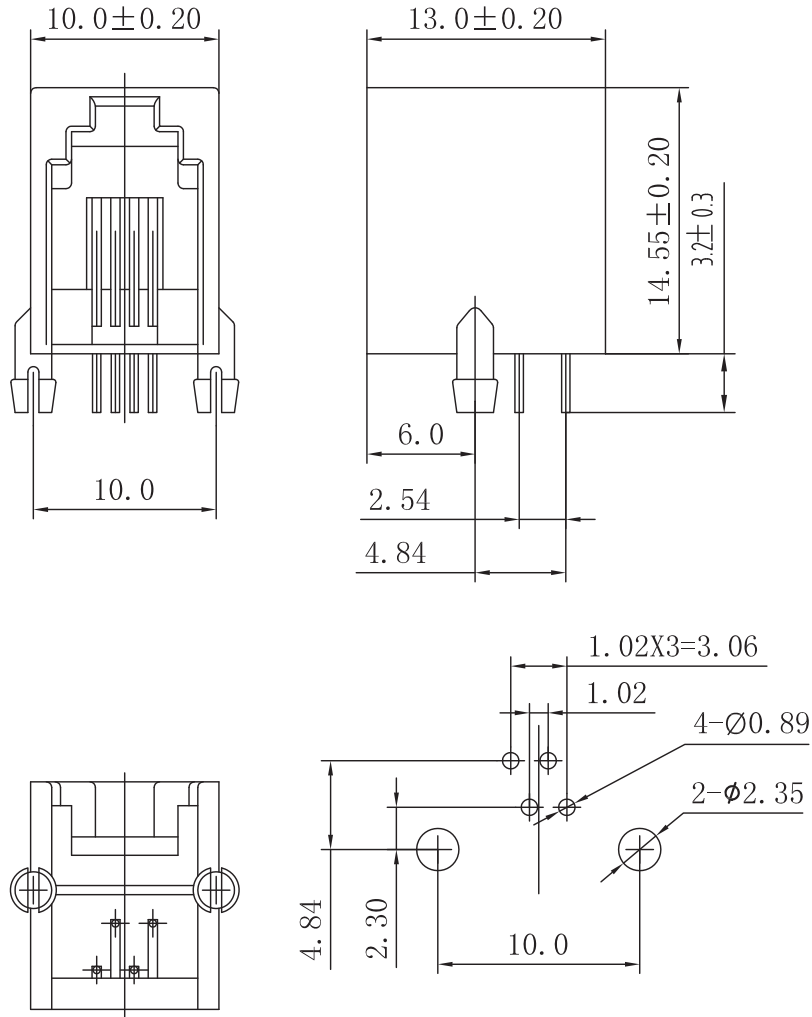

RECOMMENDED PCB LAYOUT
(COMPONENT SIDE VIEW)

SPECIFICATION AND PERFORMANCE



1 Scope

This specification covers the requirements for product performance, tests and quality assurance provisions for side entry PCB jack

2 Applicable document

The following documents form a part of this specification to the extent specified herein. In the event of conflict between the requirements of this specification and the product drawing shall take precedence

3 Materials

Plastic Housing:thermoplastic PBT flammability rating UL94V-0.
(color:pantone Gray)
Contact: phosphor bronze $\varnothing=0.46\text{mm}$ round Pin
Plating: F u' Gold plating over nickel
PCB retention fre-solder:1LB min.

4.Mechanical characteristics:

Durability:750(modular jack) insertion/plug dimension cycles
Mates with modular plug conforming to FCC part 68 subpart F

5.Electrical

Current rating: 1.5AMP
Voltage rating: 125VAC max.
Contact resistance: 30 milliohms max.
Insulation resistance: 500 megohms min.@500 VDC.
Dielectric strength: 1000 VAC RMS 60Hz, 1min.

6.Environmental:

Operating temperature: $-40^{\circ}\text{C}\sim+85^{\circ}\text{C}$
Storage temperature: $-40^{\circ}\text{C}\sim+85^{\circ}\text{C}$

7.Applicable printed circuit board

The product is designed to meet the electrical, mechanical and environmental performance requirements specified in product drawing

TITLE 4P4C SIDE ENTRY PCB JACK WITHOUT SHIELDED				DELEC		东莞多亚电子有限公司 DONGGUAN DUOYA ELECTRONICS CO., LTD			
PART NO. DY9755-1D21038-001				GENERAL TOLERANCE				UNIT:MM(INCH)	SIZE: A4
DRAW	Star	DATE	2015-06-23	$.X\pm 0.20$	$.X\pm 1^{\circ}$	SCALE: 1:1		SHEET: 3/4	REV:A
CHECK	Eric	DATE	2015-06-23	$.XX\pm 0.15$	$.XX\pm 0.5^{\circ}$				
APPROVE	De	DATE	2015-06-23	$.XXX\pm 0.10$					

PACKAGE INFORMATION AND LABEL

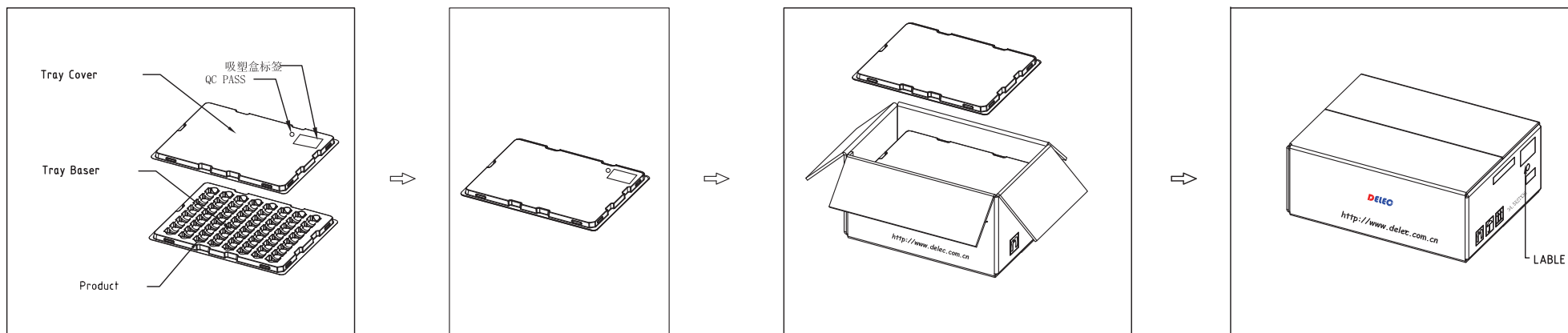

PACKING QUANTITY : 198 PCS FINISHED GOODS PER TRAY
 20 TRAYS (3960 PCS FINISHED GOODS) PER CARTON BOX

TITLE 4P4C SIDE ENTRY PCB JACK WITHOUT SHIELDED						东莞多亚电子有限公司 DONGGUAN DUOYA ELECTRONICS CO., LTD			
PART NO. DY9755-1D21038-001				GENERAL TOLERANCE				UNIT:MM(INCH)	SIZE: A4
DRAW	Star	DATE	2015-06-23	.X±0.20	.X±1°	SCALE: 1:1	SHEET: 4/4	REV:A	
CHECK	Eric	DATE	2015-06-23	.XX±0.15	.XX±0.5°				
APPROVE	De	DATE	2015-06-23	.XXX±0.10					