

PRODUCT SPECIFICATION DRAWING

FIG : 平型公端子

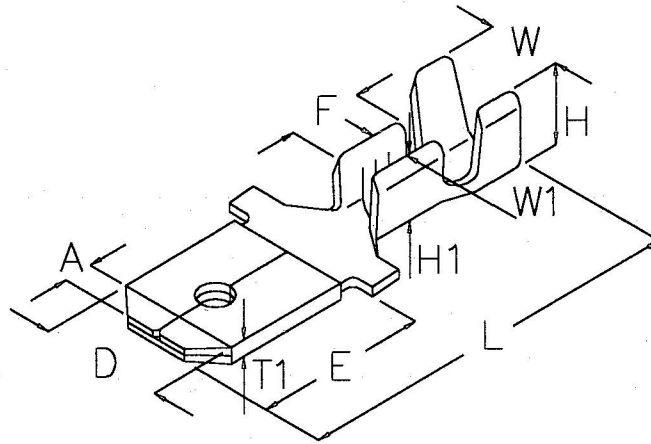

WIRE GAUGE AWG	DIMENSIONS T x W x P	STD PKG Q'TY	NW KGS	MATERIAL /FINISH	SURFACE PROCESS	SERIAL OR SINGLE TYPE
12-16	-----	--	-- kg	Brass 1/2H	-0 -2	Serial

ITEM	SPECIFICATION	REMARK	ITEM	SPECIFICATION	REMARK
T	0.4 ±0.03				
T1	0.8 $\begin{matrix} +0.04 \\ +0.0 \end{matrix}$				
L	20.3 ±0.25				
E	8.4 ±0.25				
D	6.35 ±0.10				
A	1.4 ±0.20				
W	6.0 ±0.30				
W1	4.0 ±0.20				
H	5.1 ±0.20				
H1	4.0 ±0.20				
F	3.7 ±0.20				

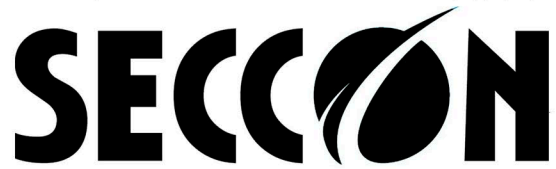

DIMENSION MEASURING SCALE UNIT : mm				PART NO : G-99676BS-2		
APPROVAL		AUDITOR		DRAWNER	ROSE	DATE : 2000 12/11
					SCALE : 2/1	