

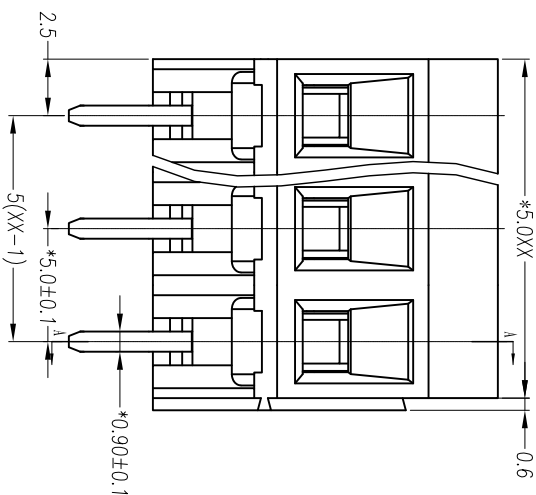

# 慈溪市万捷电子有限公司 CIXI WANJIE ELECTRONIC CO., LTD

产品规格书  
THE SPEC SHEET

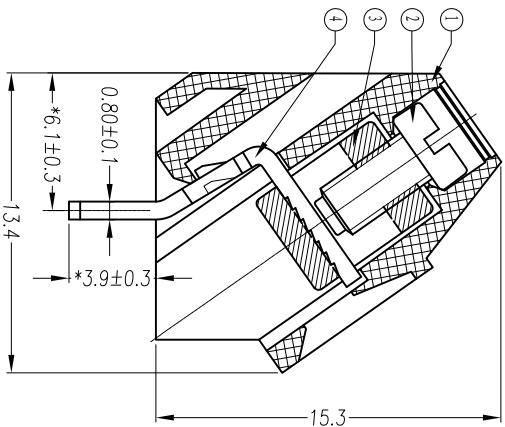
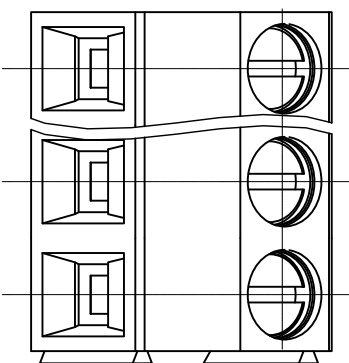
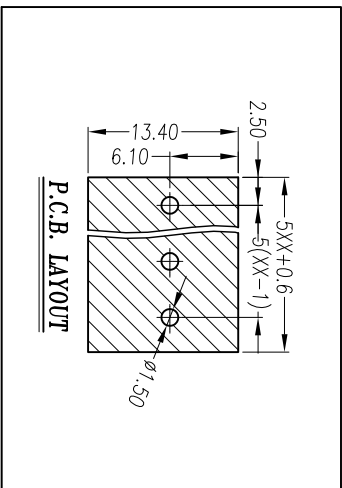

### 电气性能/Electrical

参考标准/Standard	UL	IEC
额定电压/Rated voltage	300V	250V
额定电流/Rated current	10A	18A
接触电阻/Contact resistance	20m $\Omega$	
绝缘电阻/Insulation resistance	500M $\Omega$ /DC500V	
使用线径/Wire range	24~12AWG	2.5mm <sup>2</sup>
耐电压/With standing voltage	AC 2000V/1 Min	

### 机械性能/Mechanical

最大扭矩/Torque	0.4Nm(3.6l.b.in)
剥线长度/Strip Length	6-7mm
温度范围/Temp. Range	-40°C~+105°C
瞬时温度/MAX Soldering	+250°C, for 5 Sec

### 尺寸/Dimensions

间距/Pitch	5.0mm
极数/Poles	2~24p

### 材料及电镀/Material

塑件/Housing	PA66, UL94V-0
螺丝/Screws	M2.5 Steel Zn plated
焊脚/Pin header	Brass 0.8t Tin plated
方块/Cage	Brass Ni plated

linear dimension variable range tolerance	over 6 to 6	over 10 to 10	over 18 to 18	over 30 to 30	over 50 to 50	over 80 to 80	over 120 to 120	over 160 to 160	over 200 to 200	over 250 to 250	all	over 5 to 5	over 30 to 30	over 120 to 120	
	$\pm 0.1$	$\pm 0.14$	$\pm 0.19$	$\pm 0.25$	$\pm 0.32$	$\pm 0.43$	$\pm 0.57$	$\pm 0.72$	$\pm 0.88$	$\pm 1.05$	$\pm 1.25$	0.5	0.025	0.06	0.12

第三视图/THIRD ANGLE PROJECTION



单位/UNITS	mm	尺寸/SIZE	A4	比例/SCALE	3:1
名称/TITLE	慈溪市万捷电子有限公司 CIXI WANJIE ELECTRONIC CO., LTD				WJ103-5.0-XXP-1YY-00A



慈溪市万捷电子有限公司  
CIXI WANJIE ELECTRONIC CO., LTD