

NO.	DATE	REVISION	REVISER	VERSION

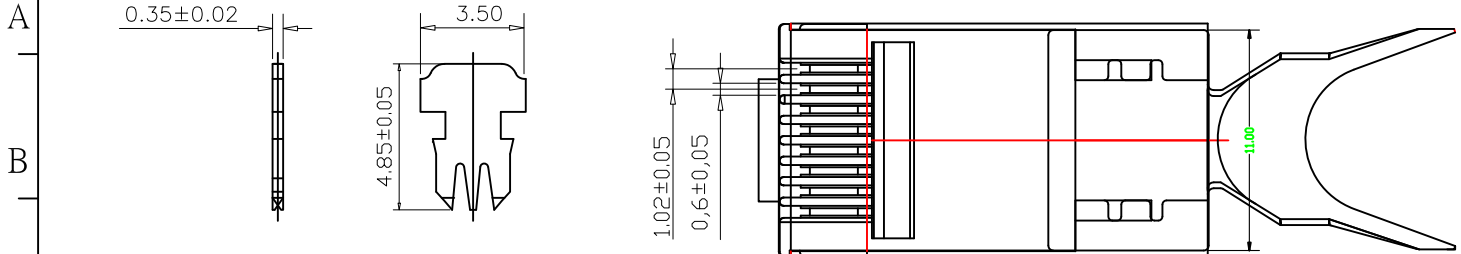

長 PIN

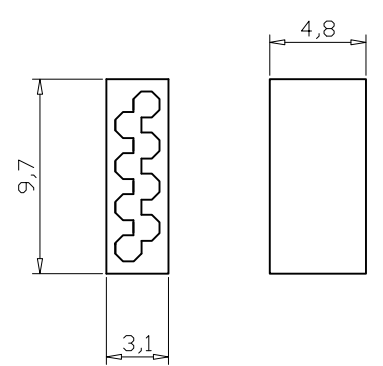
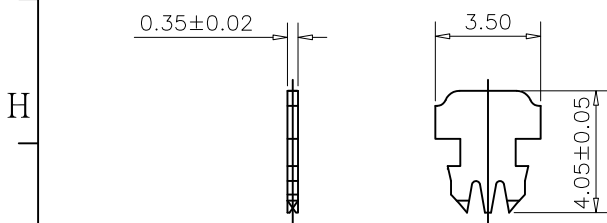
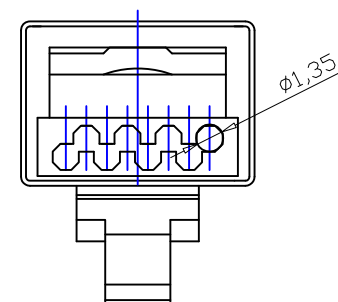
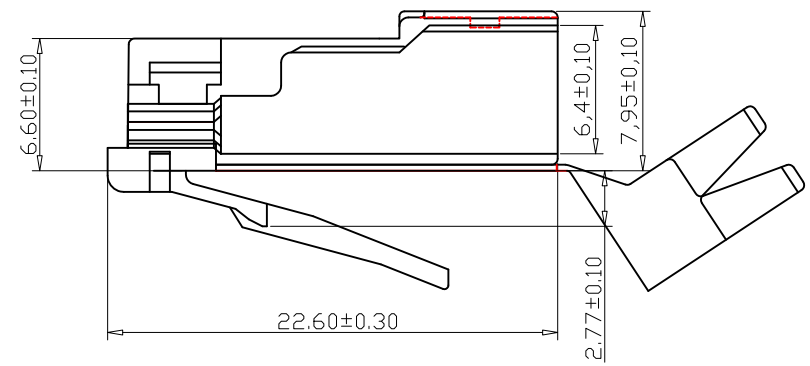
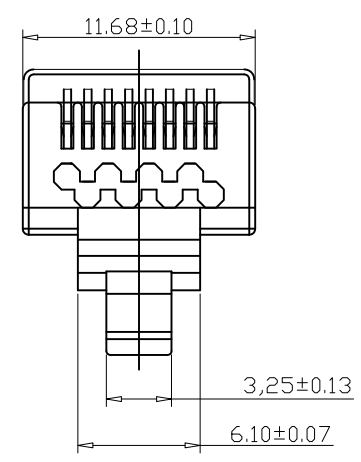

NOTES UNLESS OTHERWISE SPECIFIED
 1. MATERIAL OF HOUSING: PC. 94-V2
 2. MATERIAL OF CONTACT: BRASS C2680
 3. MATERIAL OF SHIELD: SPCC NICKEL PLATING
 4. ELECTRICAL TEST:
 Dielectric withstanding volts:500AC
 Insulation Resistance:500mega ohms
 Termination Resistance:35milliohms max

APPROVED	J.S.Zhong	PC	通孔式七类屏蔽 OD:1.3MM	m/m	W&T	
CHECKED		MATERIAL	NAME	UNIT		
DRAWN		DWG NO.	PART NO.	WEIGHT		GENERAL TOLERANCE
DESIGNED	Y.Cheng	TP	Molding	1:1		A/O
		COLOR	MANUFACTURE	SCALE	SURFACE ROUGHNESS	VERSION